

PARTS SCHEDULE

ITEM NO.	NAME	MATERIAL	QTY
1	BODY		1
2	SEAT RING		1
3	DISC		1
4	STEM		1
5	RETAINER RING		1
6	PACKING		1 SET
7	PACKING GLAND		1
8	GLAND FLANGE		1
9	GLAND BOLT		2
10	NUT		2
11	SPRING WASHER		2
12	BUSH BEARING		2
13	DISC PIN		2
14	PACKING RETAINER		1
15	CAP PACKING		1
16	CAP		1
17	CAP BOLT		4
18	SPRING WASHER		4
19	SEAT RETAINER		1
20	RETAINER BOLT		4

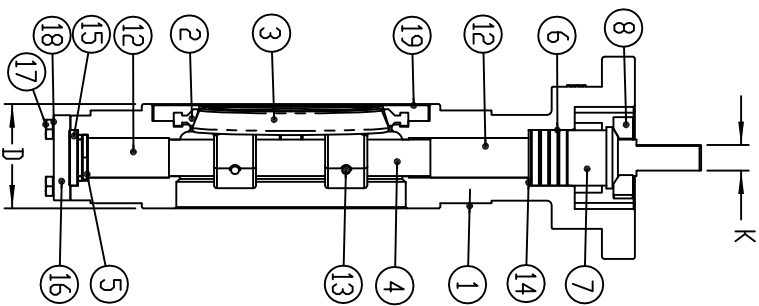
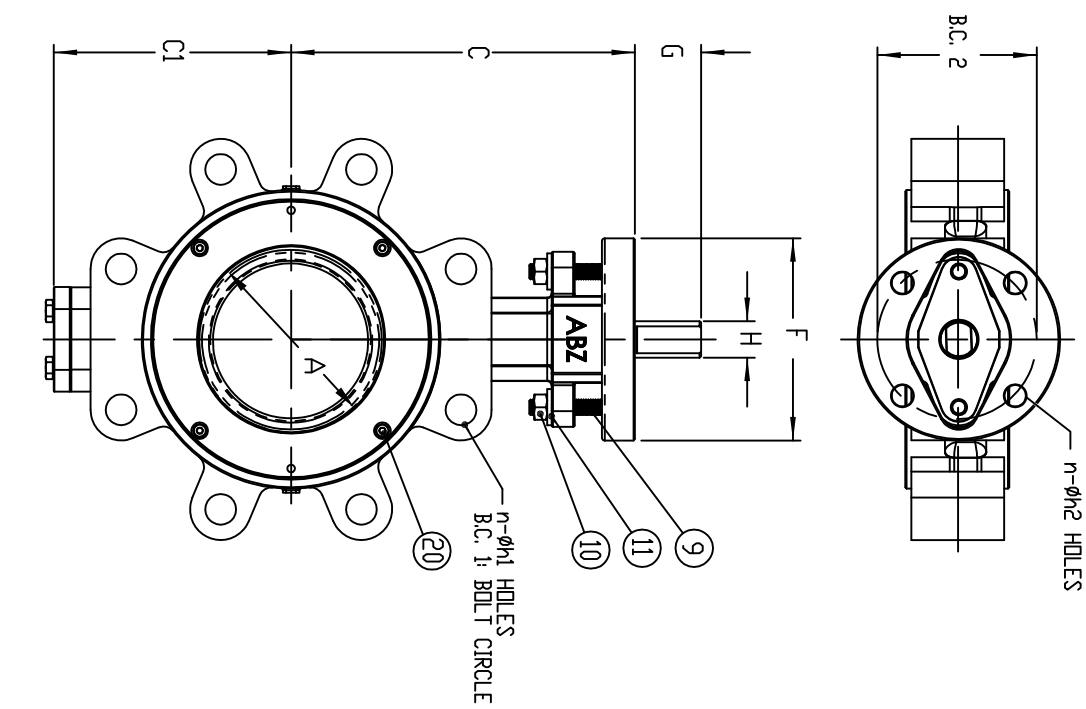

DIMENSIONS

VALVE SIZE	INCH	MM	ØA	C	C1	D	ØF	G	ØH	K	FLANGE DIMENSION			MOUNTING BASE		
											B.C. 1	n	Øh1	B.C. 2	n	Øh2
3	80	287	6.57	4.92	2.17	4.02	1.18	.748	.500	.500	6.62	8	3/4-10 UNC	3.25	4	.430
4	100	354	7.68	5.71	2.52	5.98	1.26	.874	.626	.626	8.50	8	7/8-9 UNC	5.00	4	.550
5	125															
6	150	504	9.45	8.07	3.07	5.98	2.24	1.374	.31x.31 KEY	.31x.31 KEY	11.50	12	1-8 UNC	5.00	4	.550
8	200	6.77	11.42	9.45	4.06	8.03	2.99	1.874	.50x.50 KEY	.50x.50 KEY	13.75	12	1 1/8-8 UNC	6.50	4	.830
10	250	8.86	13.19	11.02	4.61	8.03	2.99	1.874	.50x.50 KEY	.50x.50 KEY	17.00	16	1 1/4-8 UNC	6.50	4	.830
12	300	10.71	15.16	12.72	5.51	11.42	4.02	2.358	.75x.50 KEY	.75x.50 KEY	19.25	20	1 1/4-8 UNC	10.00	8	.750

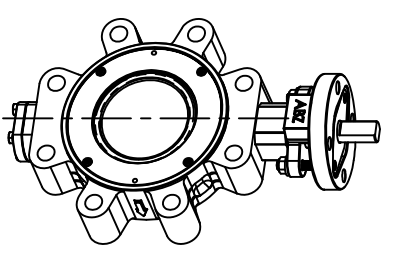

ABZ Valves & Controls

HIGH PERFORMANCE
3'-12" FIGURE 452 VALVE
DOUBLE OFFSET
CLASS 600
STANDARD LUGGED PATTERN
DIMENSIONS SUBJECT TO
CHANGE WITHOUT NOTICE



DATE: 06-01-07 REV: 1

DRAWING NO. 3-12 600 FIG 452