

Moniteur

Installation and Operating Instructions VPT Series

CAUTION: Always check that the electrical load is within the range stated on the nameplate. Failure to adhere to the ratings may result in damage to or premature failure of the electrical switches or sensors.

ELECTRICAL SPECIFICATIONS

MECH.	Code	Switch Type	AC Rating	DC Rating	Form
	1	Cherry - SPDT	15A - 250V	2.5A - 24V	C
	3	Prism Gold Plated - SPDT	1A - 120V	1A - 24V	C
	4	ITW - DPDT	10A - 250V	7A - 24V	CC

TTL	Code	Switch Type	AC Rating	DC Rating	Form
	2	Tungsten TTL - SPDT	3A - 120V	2A - 24V	C
	E	Tungsten TTL HV - SPDT	0.4A - 240V	0.4A - 240 V	C
	7	Rhodium TTL - SPST	1A - 120V	1A - 24V	A
	T	Rhodium TTL - SPDT	1A - 120V	1A - 24V	C
	L	Krystal TTL - SPDT	0.3A - 120V	0.3A - 24V	C
	B	Bifurcated TTL - SPST	3A - 120V	2A - 24V	A



INDUCTIVE	Code	Sensor	Supply Voltage	Load Current / Target Absent	Load Current / Target Present	Operation
	8	P & F NJ2-V3	5-25 VDC	< 1 mA	3 - 15 mA	NAMUR
	K	P & F NBB3-V3-Z4	5-60 VDC	< 0.7 mA	4 - 100 mA	PNP
	M	Moniteur NAMUR	5-25 VDC	< 1 mA	3 - 15 mA	NAMUR
	A	Moniteur NEO-X	10-250 VAC/VDC	< 1 mA	3 - 300 mA	NO

Note: In Survivor II enclosures, Voltage and Current Ratings are lower, see Nameplate for appropriate ratings.

WARNING: All Inductive Sensors must be connected with the appropriate PLC, microprocessor or relay load. Otherwise, damage can result to the sensors. Check the sensor installation sheet in the box.

WIRING OF VALVE POSITION TRANSMITTER

- Remove VPT cover from the housing by loosening the screws. Holding the housing and cover assembly together, lift the cover from the housing.
- Follow the wiring diagram located inside the cover of the VPT. Be sure to secure all the appropriate connections including the ground. The diagram at left relates the wiring diagram to the terminal block.
- Replace the VPT cover and tighten the screws. To ensure that the shaft alignment mechanism functions properly, bring all of the screws in contact with the cover and then tighten them in stages moving from one screw to its diagonal counterpart.

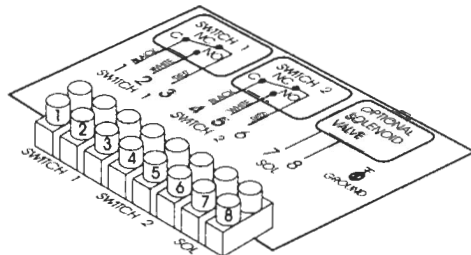

TERMINAL BLOCK AND WIRING DIAGRAM

WARNING (FOR ENCLOSURE TYPES 4, 4x, 7 and 9 ONLY): To prevent fire or explosion, use only with a seal fitting within 18 inches of the position transmitter enclosure.

CLEANING VALVE POSITION TRANSMITTER

If desired, use a damp rag or cloth to clean the outside of the position transmitter. No routine cleaning or maintenance is required for reliable, long term operation of the device.

WARNING: If the equipment is used in a manner not specified by the manufacturer, the protection provided by the equipment may be impaired.

Moniteur

Installation and Operating Instructions VPT Series - Form IO1-0202

DESCRIPTION OF DEVICE

The Moniteur Visual Indicator is a mechanical device that graphically displays the angular displacement of a quarter turn valve or any other device operating between 0 and 90 degrees. The Moniteur Indicator represents a true indication of valve position. It is infinitely adjustable, and delivers a 100% change of indication, displaying 90 degrees of rotation by utilizing an amplified mechanical drive. Moniteur Valve Position Transmitters have enclosures meeting the following requirements:

Sentinel - Nema 4, 4x - Watertight, Nema 7 Explosion-proof and Nema 9 Dust - Ignition-proof, Class 1, Division 1 Groups C&D, Class I, Division 1 Groups E, F, & G, Class 1, Division 2 Groups A, B (TTL switches and Inductive Sensors only)

Sentinel II - Nema 4, 4x Watertight, Nema 7 Explosion-proof and Nema 9 Dust - Ignition-proof, Class 1, Division 1 Groups A, B, C&D, Class II, Division 1, Groups E, F, & G

Watchman / Watchman II / Survivor / Scout - Nema 4, 4x - Watertight

Survivor II - Nema 4, 4x - Watertight, Series 'Q' (FM) Install per drawing no. S2CF Non-incendive Division 2 All Groups Series 'R' (CSA) Division 2 All Groups

The Survivor II unit must be supplied by an SELV source in accordance with C22.2 No. 1010.1 Annex H.

PART NUMBER SYSTEM

The series and part number are located on the nameplate. The part number can be deciphered in the table below.



Description	Code	Description	Code	Description	Code
Series		Bearing		Rhodium TTL 1A	
Sentinel	A	Bronze	B	SPDT Non-Contact	T
Sentinel-II	C	303 Stainless Steel	S	Bifurcated TTL 3A	
Watchman	F			SPST Non-Contact	B
Watchman-II	H			P&F NJ2-V3 NAMUR	
Survivor	P	Shaft		Inductive Sensor	8
Survivor-II (FM)	Q	Standard 303 SS	1	P&F NBB3-V3-Z4	
Survivor-II (CSA)	R	Standard 316 SS	3	Inductive Sensor	K
Scout	V	NAMUR 303 SS	5		
Indicateur	I	Long NAMUR 303 SS	E	Switch Quantity	1-6
Cover				Conduit (Watchman / Survivor)	
With Moniteur	M			(2) 1/2" F NPT	0
Fiat Cover (No Moniteur)	F			(3) 1/2" F NPT	6
				(1) 1/2" F + (1) 1/2" M NPT	8
Moniteur				Conduit (Sentinel)	
No Indicator	N			(2) 1/2" F NPT	0
Black / Yellow	Y			(3) 1/2" F	5
3-Way Path O,T,F	O,T,F			(2) 1/2" F + (1) 1/2" F NPT	6
4-Way Path S	S			(1) 1/2" F + (1) 1/2" M NPT	8
180 degree "T"	1			Output (add suffix to part number)	
Green, Red, Blue / White	G,R,B			Current 4 - 20mA	- 420
Green / Red	A			Resistive 0 - 1kΩ	- 1K
Red / Green	C				
0-100%	P				

CAUTION: To reduce the risk of ignition of hazardous atmospheres, disconnect the device from the supply circuit before opening. Keep assembly tightly closed during operation.

Pollution Degree - "4"
Installation Category - "I"
Operating Temperature (deg. C) -40 to 80

Positioning- Moniteur Valve Position Transmitters can be mounted in any position.

Mounting Dimensions (for all switches)

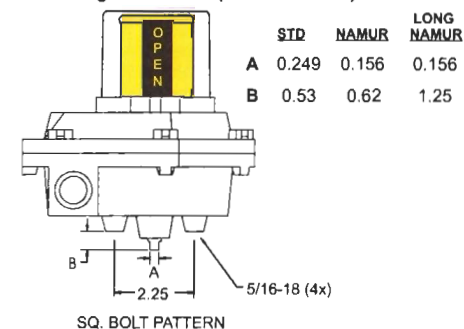

	STD	NAMUR	LONG NAMUR
A	0.249	0.156	0.156
B	0.53	0.62	1.25

INSTALLATION - ADJUSTING THE VISUAL INDICATOR

1. Mount the valve position transmitter to the valve or actuator with the correct mounting bracket.
2. Determine the true valve position and compare the Moniteur's Indication with the true valve position. If the Moniteur display is synchronized, proceed to Step 12. If it is not, continue to Step 3.
3. Remove the clear Moniteur cover by turning it counter-clockwise to disengage the detent and then lift it off. Determine the level of adjustment that needs to be made. If only a small adjustment is necessary (less than 20 degrees in either direction), proceed to step 4. If a larger adjustment is required, such as 45, 90 or 135 degrees from default, proceed to step 7.
4. Remove the Moniteur Visual Indicator by lifting it upward off the shaft and the Infinite Adjusting Ring. Loosen screws B and C shown in fig.1 (do not remove screws). The Infinite adjusting ring should rotate freely over the enclosure cover of the Valve Position Transmitter.
5. Return the Moniteur Indicator to the output shaft. As it slides down along the shaft, be sure that the Moniteur Indicator's base engages the Infinite Adjusting Ring on pins "E". (fig.1)
6. Rotate the Moniteur Indicator by applying a light rotational force to the vertical vanes to synchronize it with the true valve position. Once aligned, proceed to Step 9. If further adjustment is necessary, you will need to continue with Step 7.
7. Remove the Moniteur Visual Indicator by lifting it upward off the shaft and the Infinite Adjusting Ring. Remove screws B and C from the Infinite Adjusting Ring. Rotate the setting ring and match the number on the plastic ring with the number cast into the enclosure, according to the following requirements:
90 - 90: as shipped from the factory - shipped as "Open".
45 - 45: "Open" is 45 degrees CCW in travel from default.
135 - 135: "Open" is 45 degrees CW in travel from default.
180 - 180: "Open" is 90 degrees CW or CCW from default.
 (This is the setting to switch default indication from Open to Closed.)
 Return screws B and C to their appropriate threaded holes, but do not tighten them completely. Now return the Moniteur Indicator to the output shaft. Be sure that the Indicator's base engages the infinite adjusting ring on pins "E". (fig.1)
8. Rotate the Moniteur Indicator by applying a light rotational force to the vertical vanes to further synchronize the Indicator with the true valve position.
9. Remove the Moniteur Indicator, being careful not to rotate the Infinite Adjustment Ring. Hold Ring stationary and tighten screws B and C.
10. Return the Moniteur Indicator being certain that both the output shaft and pins "E" of the Infinite Adjusting Ring are engaged.
11. Return the clear Moniteur cover by inserting it into the breach lock on the enclosure cover and turning it Clock-wise until the unit engages the detent.
12. Cycle the valve to the opposite extremity. If the Moniteur Indicator is displaying the correct valve position, installation is complete. If not, it is probably because the actuator is not moving exactly 90 degrees. Adjust the stroke of the actuator so that it is rotating 90 degrees and the Moniteur Indicator will indicate the correct valve position. Installation is now complete.

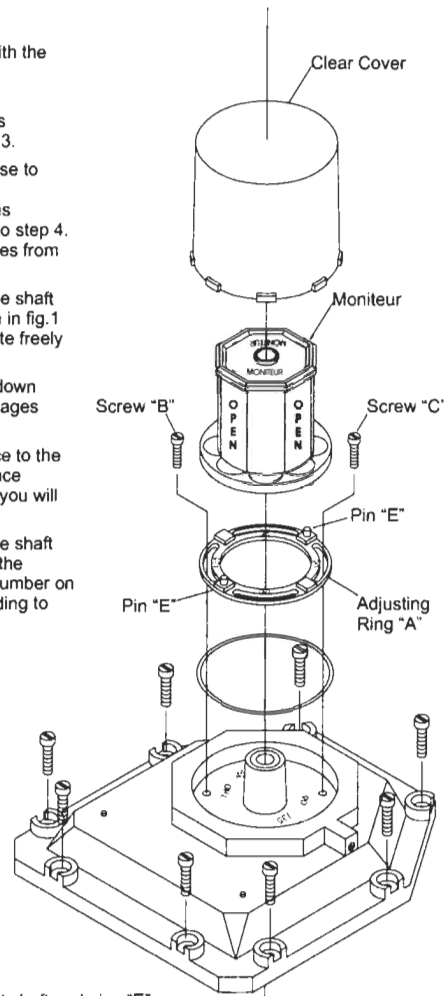
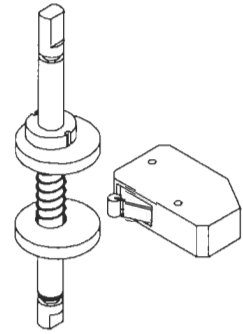

Fig. 1

WARNING: To prevent the possibility of personal injury or property damage, turn off electrical power before inspection, adjustment, or removal of the valve position transmitter.

INSTALLATION - SETTING MECHANICAL SWITCHES (Switch Types 1, 3 and 4)

1. Remove VPT cover from the housing by loosening the screws holding the housing and cover assembly together.
2. Move the valve or valve actuator assembly to a position where one or more of the switches will be required to operate noting the direction of VPT shaft rotation.
3. Determine which switch is to be set and lift or depress the corresponding cam as required. Rotate the cam in the direction of shaft rotation until the cam engages the switch and closes the normally open contact for SPDT and DPDT switches.
4. Repeat Steps 2 and 3 until all of the switches are set.
5. Replace the VPT cover and tighten the screws. To ensure that the shaft alignment is secured, bring all of the screws in contact with the cover and then tighten them in stages moving from one screw to its diagonal counterpart.



INSTALLATION - SETTING TTL MAGNETIC SWITCHES (Switch Types 2, T and B)

NOTE: To properly set switches, an ohm meter or equivalent devices will be required.

1. Remove VPT cover from the housing by loosening the screws holding the housing and cover assembly together.
2. Move the valve or valve actuator assembly to a position where one or more of the switches will be required to operate noting the direction of VPT shaft rotation.
3. Determine which switch is to be set and lift or depress the corresponding cam as required. Using the arrow only as a guide, rotate the cam in the direction of shaft rotation until the circle on the cam and the arrow on the switch are aligned with each other. **IMPORTANT -** To be sure the normally open contact is now closed, you must use an ohm meter or equivalent device to check the setting.
4. Repeat Steps 2 and 3 until all of the switches are set.
5. Replace the VPT cover and tighten the screws. To ensure that the shaft alignment is secured, bring all of the screws in contact with the cover and then tighten them in stages moving from one screw to its diagonal counterpart.

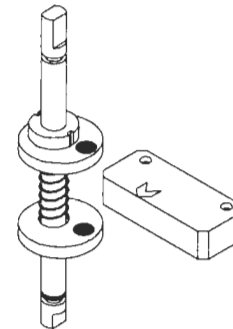

INSTALLATION - SETTING INDUCTIVE SENSORS (Switch Types 8, K and M)

NOTE: To properly set sensors, an appropriate sensor tester will be required.

1. Remove VPT cover from the housing by loosening the screws holding the housing and cover assembly together.
2. Move the valve or valve actuator assembly to a position where one or more of the sensors will be required to operate noting the direction of VPT shaft rotation.
3. Determine which switch is to be set and lift or depress the corresponding cam as required. Using the target area only as a guide, rotate the cam in the direction of shaft rotation until the pin on the cam and the target area on the sensor are aligned with each other. If the sensor has an LED, it should light now. **IMPORTANT -** To be sure the sensor is now actuated you must use an appropriate sensor tester.
4. Repeat Steps 2 and 3 until all of the sensors are set.
5. Replace the VPT cover and tighten the screws. To ensure that the shaft alignment is secured, bring all of the screws in contact with the cover and then tighten them in stages moving from one screw to its diagonal counterpart.

